

POWER ELECTRONICS

BY

**SURESH RANI
LECTURER ECE
GP JHAJJAR**

Power Electronics

1.1 What is Power Electronics?

Power electronics is the branch of engineering that deals with:

- Conversion of electrical power
- Control of electrical power
- Using power semiconductor devices

Explanation:

Normal electronics deals with small signals (like audio, radio). Power electronics deals with **large power** (high voltage and current), such as motors and power supplies.

1.2 Need for Power Electronics

Power electronics is required to:

- Control motor speed
- Convert AC to DC or DC to AC
- Improve efficiency
- Save energy

Example:

A fan regulator uses power electronics to control fan speed.

1.3 Applications of Power Electronics

Power electronics is used in:

- Electric vehicles
- Solar power systems
- UPS
- Battery chargers
- Industrial drives

Explanation:

All modern electrical systems need controlled power, which is done using power electronics.

POWER SEMICONDUCTOR DEVICES

2.1 Power Diode

Definition:

A power diode is a semiconductor device that allows current to flow in **one direction only**.

Explanation:

It blocks current in reverse direction and is mainly used to convert AC into DC.

Application: Rectifiers

2.2 SCR (Silicon Controlled Rectifier)

Definition:

SCR is a three-terminal device used as a **controlled switch**.

Terminals:

- Anode
- Cathode
- Gate

Explanation:

SCR turns ON only when a gate pulse is applied and remains ON until current falls to zero.

Applications:

- Motor control
 - Battery chargers
-

2.3 TRIAC

Definition:

TRIAC is a bidirectional thyristor used to control AC power.

Explanation:

Unlike SCR, TRIAC conducts current in **both directions**, making it suitable for AC circuits.

Applications:

- Fan regulator
 - Light dimmer
-

2.4 MOSFET

Definition:

MOSFET is a voltage-controlled power device.

Explanation:

It switches very fast and is used in high-frequency circuits.

Applications:

- SMPS
 - Inverters
-

2.5 IGBT

Definition:

IGBT is a combination of MOSFET and BJT.

Explanation:

It provides high voltage and current handling with fast switching.

Applications:

- Electric vehicles
 - Industrial motor drives
-

RECTIFIERS & AC VOLTAGE CONTROLLERS

3.1 Rectifier

Definition:

A rectifier converts **AC power into DC power**.

3.2 Types of Rectifiers

(a) Half Wave Rectifier

- Uses one diode
- Converts only one half of AC into DC

Explanation:

Output is pulsating DC with low efficiency.

(b) Full Wave Rectifier

- Uses two diodes
- Uses both half cycles of AC

Explanation:

Better efficiency than half wave rectifier.

(c) Bridge Rectifier

- Uses four diodes
- No center-tapped transformer needed

Explanation:

Most commonly used rectifier.

3.3 AC Voltage Controller

Definition:

AC voltage controller controls AC voltage without changing frequency.

Explanation:

By controlling the firing angle of SCR or TRIAC, output voltage is changed.

Applications:

- Heater control
 - Fan speed control
-

CHOPPERS (DC–DC CONVERTERS)

4.1 What is a Chopper?

A chopper converts **fixed DC voltage into variable DC voltage**.

Explanation:

It works like a switch that turns ON and OFF rapidly.

4.2 Types of Choppers

(a) Step-Down Chopper

- Output voltage < Input voltage

Explanation:

Used to reduce voltage for DC motor speed control.

(b) Step-Up Chopper

- Output voltage > Input voltage

Explanation:

Used in regenerative braking.

5.1 What is an Inverter?

An inverter converts **DC power into AC power**.

Explanation:

Battery supplies DC, but AC is required for household appliances.

5.2 Types of Inverters

(a) Single-Phase Inverter

- Used for low power

Example: Home UPS

(b) Three-Phase Inverter

- Used for industrial motors
-

6.1 Protection of Power Devices

Why protection is needed?

Power devices can get damaged due to excess current or voltage.

Protection methods:

- Fuse
 - Circuit breaker
 - Snubber circuit
-

6.2 Cooling of Power Devices

Explanation:

Power devices generate heat during operation.

Cooling methods:

- Heat sinks
- Air cooling
- Forced cooling

Role of Power electronics:

The systems and machines of the world run efficiently and sustainably due to use of power electronics. Power electronics is the application of solid-state electronics for the control and conversion of electric power. Power electronics convert and controls the flow of electrical energy needed for everyday products to be delivered with maximum efficiency. Role of power electronics is very important in modern day life and can be understood from following applications:

- 1) **Our Daily Life:** There are lot of power electronics applications in our daily life such as a fan regulator, light dimmer, air-conditioning, induction cooking, emergency lights, personal computers, vacuum cleaners, UPS (uninterrupted power system), battery charges, etc.
- 2) **Automotive and Traction:** Subways, hybrid electric vehicles, trolley, fork-lifts, and many more. A modern car itself has so many components where power electronic is used such as ignition switch, windshield wiper control, adaptive front lighting, interior lighting, electric power steering and so on
- 3) **Industries:** Almost all the motors employed in the industries are controlled by power electronic drives.
- 4) **Defense and Aerospace:** Power supplies in aircraft, satellites, space shuttles, advance control in missiles, unmanned vehicles and other defence equipments make use of power electronics.
- 5) **Renewable Energy:** Generation systems such as solar, wind etc. needs power conditioning systems, storage systems and conversion systems, where power electronics plays an important role.
- 6) **Utility System:** HVDC transmission, VAR compensation (SVC), static circuit breakers, FACTS and smart grids etc. make use of power electronics.

Construction of SCR: It is a four-layer (p-n-p-n) semiconductor device which consists of three terminals. Three terminals of SCR are: (1) Anode (2) Cathode (3) Gate

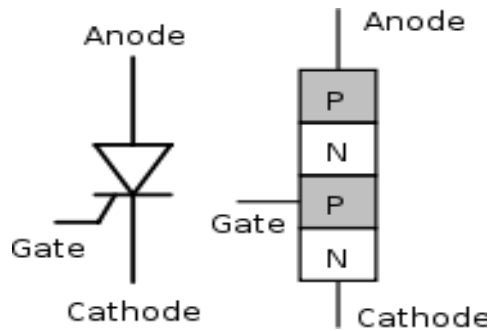

Fig. 1.1 Symbol and Construction View of SCR

- ❖ The terminal connected to outer p-layer is called anode (A)
- ❖ The terminal connected to outer n-layer is called cathode (K)
- ❖ The terminal connected to middle p-layer is called gate (G)

Working Principle of SCR:

The working principle of SCR can be explained with the help of following figures:

(a) When the anode voltage is made positive w.r.t. cathode:

- (i) The p-n junctions J1 and J3 are forward biased and junction J2 is reversed biased
- (ii) Small leakage current flow from anode to cathode.
- (iii) No conduction occurs in the SCR.
- (iv) This state of SCR is called **Forward Blocking** state of **Forward Off** state.
- (v) Now anode to cathode voltage (V_{AK}) is increased slowly and when forward voltage (V_{AK}) is reach to voltage called **Forward Breakover voltage (V_{BO})** then the junction J2 will breakdown.
- (vi) This is known as **Avalanche breakdown**.
- (vii) As the junctions J1 and J3 are already forward biased, a large amount of forward anode current start flowing through the SCR.

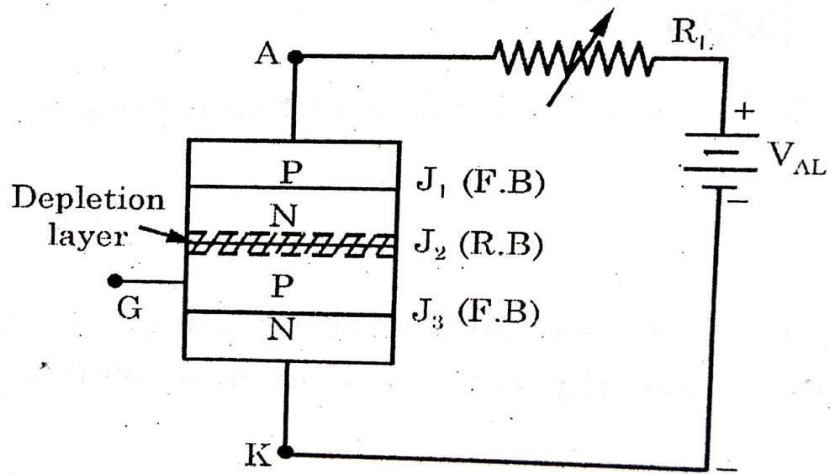

(a) SCR Forward biased.

(b) When the cathode voltage is made positive w.r.t. anode:

- (i) Junction J1 and J3 will be reversed biased and Junction J2 will be forward biased.
- (ii) A small reverse leakage current will flow.
- (iii) As the cathode to anode voltage is increased to a large value, junction J1 and J3 will breakdown.
- (iv) The voltage at which this condition is achieved is called **Reverse Breakover Voltage (VBO)**.

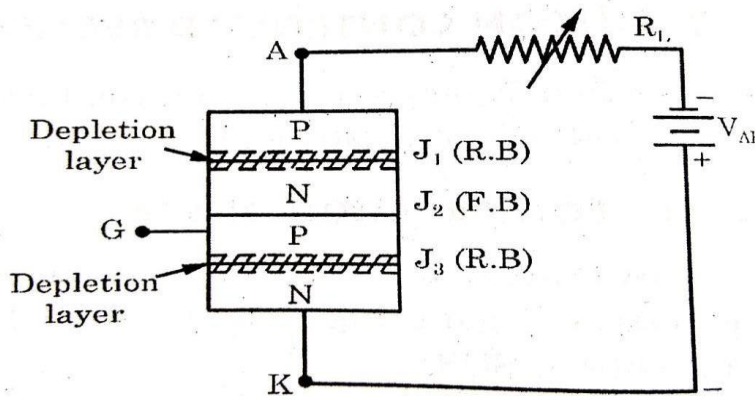

(b) SCR Reverse biased

V-I Characteristics of SCR:

V-I Characteristics of SCR are shown below in figure:

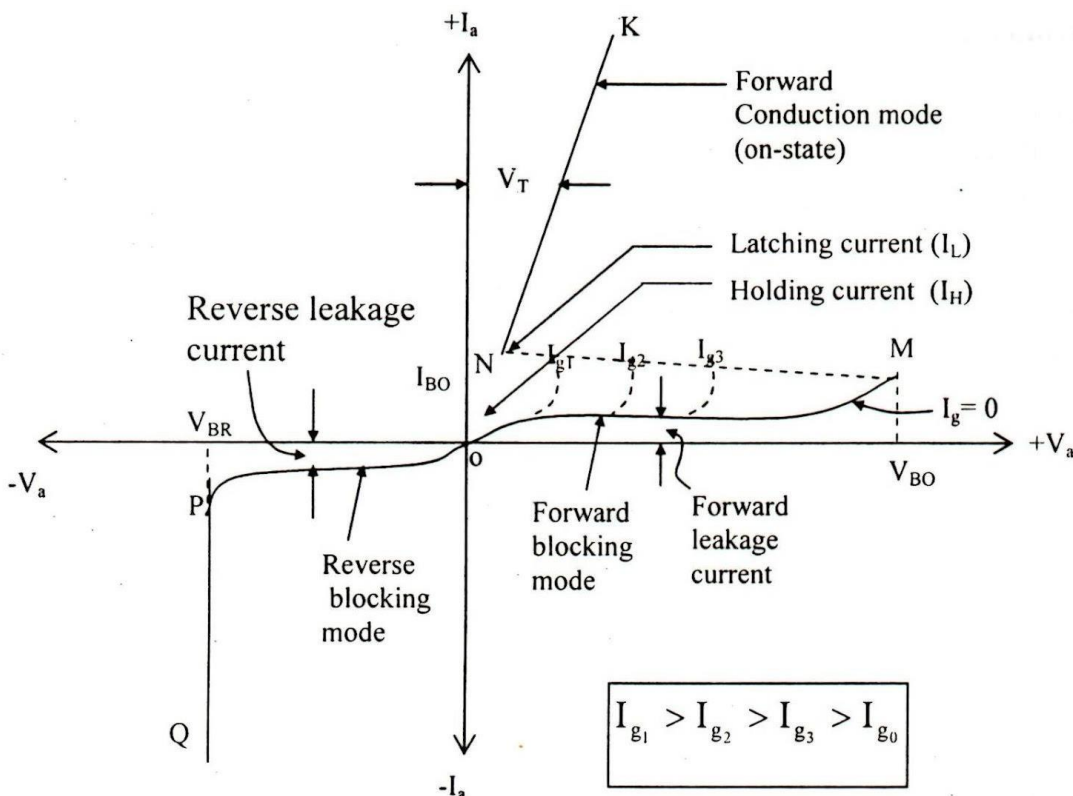

Fig 1.2 V-I Characteristics of SCR

V-I Characteristics of SCR can be explained with the help of three mode of operation:

- 1) **Forward Blocking Mode:** When the anode voltage is +ve w.r.t. cathode then the SCR is forward biased. When the forward voltage is less than forward breakover voltage (VBO) then SCR remains in OFF state and it is known as forward blocking mode.
- 2) **Forward Conduction Mode:** When anode to cathode voltage is more than forward breakover voltage (VBO), the SCR is brought from forward blocking mode to forward conducting mode. The anode current must be more than latching current (IL). If the anode current is reduced below the holding current (IH), the SCR switches back to forward blocking mode.
- 3) **Reverse Blocking Mode:** When the cathode is made +ve w.r.t. anode, the SCR is reversed biased. A small reverse leakage current flow. If the reverse voltage (cathode to anode) is increased, an avalanche breakdown will occur and large amount of reverse current start flowing. The reverse voltage at which this condition is reached is called **reverse breakdown voltage (VBR)**. This mode of operation is called Reverse Blocking Mode.

Two transistor analogy of SCR or Thyristor:

The two-transistor analogy of SCR is a method of representing an SCR as a combination of an n-p-n and a p-n-p transistor.

SCR is a three terminal device having a p-n-p-n structure. The three terminals are the cathode, anode and the gate terminal.

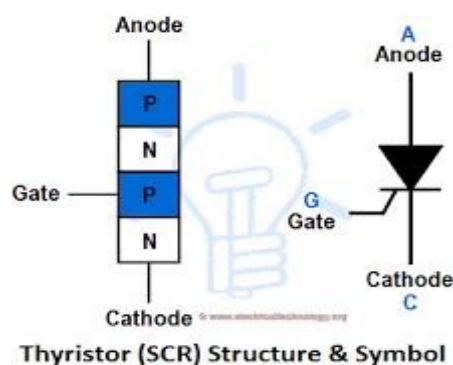

Now, the p-n-p-n structure can be reduced in the following form:

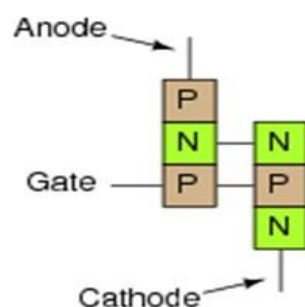

From this very representation, we can see that the top p-n-p block represents a p-n-p transistor and the bottom one represents an n-p-n transistor. This leads us to have the following two-transistor analogy of an SCR:

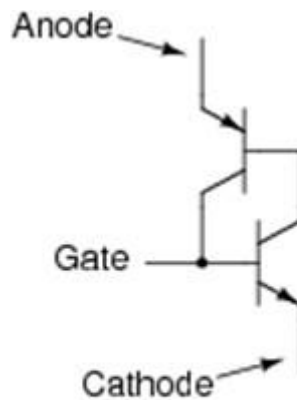

Equivalent schematic

This representation is useful for studying the working of the device, as well as for the calculation of currents by circuit analysis and using the properties of transistors.

Working of two transistor model:

- When gate signal is zero, collector current of transistor T2 (n-p-n) is almost zero & the transistor T2 is in OFF-state, even if we apply a positive voltage between anode and cathode.
- The collector current of T2 transistor is base current of T1 transistor, hence T1 transistor is also in OFF-state and the thyristor is in forward blocking state.
- Now, when the positive signal is applied to the gate terminal, the collector current start flowing into T2 transistor.
- The collector current of T2 transistor is the base current of T1 transistor, hence both T1 and T2 transistors start conducting and they come into ON-state.
- Once the SCR is in ON-state, gate loses its control and it can be turned OFF only by reducing the anode current below holding current.

SCR specifications & ratings:

The main specifications of the SCR are its voltage rating and current rating.

Voltage Rating:

Peak Inverse Voltage (PIV)

The peak inverse voltage is defined as the maximum reverse voltage (cathode positive with

respect to anode) that can be applied to an SCR without conduction in the reverse direction. It is also called as the peak reverse voltage (PRV).

On State Voltage:

The voltage which appears across the SCR during its ON state is known as its ON state Voltage. The maximum value of voltage which can appear across the SCR during its conducting state is called its maximum on state voltage. Usually it will be 1V to 4V.

Forward Breakover Voltage (V_{BO}):

The minimum voltage, which is required between the anode and cathode of an SCR to trigger it to conduction mode, is called its Forward Breakover Voltage.

Reverse Breakdown Voltage (V_{BR}):

It is the maximum reverse voltage applied between cathode to anode at which avalanche breakdown will occur in reverse biasing condition and a large amount of reverse current start flowing through the SCR.

Rate of Rise of Voltage (dV/dt) Rating:

The maximum rate at which the voltage across the device rises (for forward condition) without triggering the device, is known as its rate of rise of voltage rating.

Gate trigger voltage (V_{GT}):

It is the maximum gate voltage required to cause the gate triggering.

Current Rating:

Maximum average ON state current (I_{mac}):

This is the average value of maximum continuous sinusoidal ON state current with conduction angle 180deg, at frequency 40 to 60Hz, which should not be exceeded even with intensive cooling.

Maximum rms ON-state current: (I_{mrc})

It is the rms value of the maximum continuous sinusoidal ON state current at the frequency 40 to 60 Hz and conduction angle 180deg, which should not be exceeded even with intensive cooling.

Maximum surge - ON state Current (I_{msc})

It is the maximum admissible peak value of a sinusoidal current during a surge, which a

thyristor can withstand.

Latching Current (I_L)

It is the minimum anode current, which is required to latch the device from its OFF state to its ON state. In other words, it is the minimum current required to trigger the device. Its value is more than Holding current by 2 to 3 times.

Holding Current (I_H)

It is the minimum anode current required to hold the SCR conducting. In other words, It is the minimum current, below which the device stops conducting and returns to its OFF state.

Gate Current:

The current which is applied to the gate of the device for control purposes is known as gate current.

Minimum Gate Current:

The minimum current required at the gate for triggering the device.

Maximum Gate Current:

The maximum current which can be applied to device safely. Current higher than this will damage the gate terminal.

Turn ON time:

The time taken by the device before getting latched from its OFF state to ON state. In other words, it is the time for which the device waits before achieving its full conduction. Usually it will be 150 to 200 μ sec.

Turn OFF time:

After applying reverse voltage, the device takes a finite time to get switched OFF. This time is called as turn-OFF time of the device. Usually it will be 200 μ sec.

Rate of rise of current(dI/dt) Rating:

The maximum rate at which the current flowing in the device from anode to cathode rises is known as its rate of rise (dI/dt) of current rating. If the value of (dI/dt) is very large, local hot spots will be formed near the gate junction and may damage the thyristor. Typical (dI/dt) rating lies between 50-800 A/ μ s.

(dI/dt) and (dV/dt) protection of SCR:

dI/dt Protection of SCR

The anode current starts flowing through the SCR when it is turned ON by the application of gate signal. This anode current takes some finite time to spread across the junctions of an SCR. For a good working of SCR, this current must spread uniformly over the surface of the

junction. If the rate of rise of anode current (di/dt) is high results a non-uniform spreading of current over the junction. Due to the high current density, this further leads to form local hot spots near the gate-cathode junction. This effect may damage the SCR due to overheating. Hence, during turn ON process of SCR, the di/dt must be kept below the specified limits.

To prevent the high rate of change of current, an inductor is connected in series with thyristor. Typical SCR di/dt ratings are in range between 20- 500 ampere per microseconds.

dv/dt Protection of SCR

When the SCR is forward biased, junctions J1 and J3 forward biased and junction J2 is reverse biased. This reverse biased junction J2 exhibits the characteristics of a capacitor. Therefore, if the rate of forward voltage applied is very high across the SCR, charging current flows through the junction J2 is high enough to turn ON the SCR even without any gate signal. This is called as dv/dt triggering of the SCR which is generally not employed as it is false triggering process. Hence, the rate of rise of anode to cathode voltage, dv/dt must be in specified limit to protect the SCR against false triggering. This can be achieved by using RC snubber network across the SCR.

Working of Snubber Circuit

Hence, the protection against high di/dt and dv/dt is achieved by using a snubber circuit. This snubber circuit consists of a series combination of capacitor and resistor which is connected across the SCR. This is also consists of an inductance in series with the SCR to prevent the high di/dt. The snubber network used for the protection of SCR is shown below.

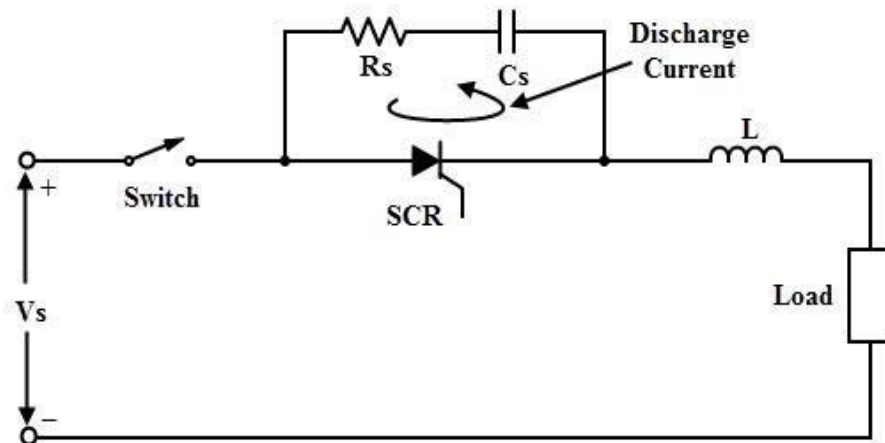

Fig. Snubber Circuit

When the switch is closed, a sudden voltage appears across the SCR which is bypassed to the RC network. This is because the capacitor acts as a short circuit which reduces the voltage across the SCR to zero. As the time increases, voltage across the capacitor builds up at slow rate such that dv/dt across the capacitor is too small to turn ON the SCR. Therefore, the dv/dt

across the SCR and the capacitor is less than the maximum dv/dt rating of the SCR.

Normally, the capacitor is charged to a voltage equal the maximum supply voltage which is the forward blocking voltage of the SCR. If the SCR is turned ON, the capacitor starts discharging which causes a high current to flow through the SCR.

This produces a high di/dt that leads to damage the SCR. And hence, to limit the high di/dt and peak discharge current, a small resistance is placed in series with the capacitor as shown in above. These snubber circuits can also be connected to any switching circuit to limit the high surge or transient voltages.

Different methods of SCR triggering:

Triggering: SCR has two stable states as forward blocking and forward conduction state. Switching the SCR from forward blocking state (OFF- state) to forward conduction state (ON- state) is known as turning ON process of SCR. It is also called as triggering.

Following are the different methods of SCR triggering:

- 1) Forward voltage triggering
- 2) dv/dt triggering
- 3) Temperature triggering
- 4) Light triggering
- 5) Gate triggering

(1) Forward Voltage Triggering

By increasing the forward anode to cathode voltage, the depletion layer width is also increasing at junction J_2 . This also causes to increase the minority charge carriers accelerating voltage at junction J_2 . This further leads to an avalanche breakdown of the junction J_2 at a forward breakover voltage V_{BO} . At this stage SCR turns into conduction mode and hence a large current flow through it. During the turn ON state the forward voltage drop across the SCR is in the range of 1 to 1.5 volts.

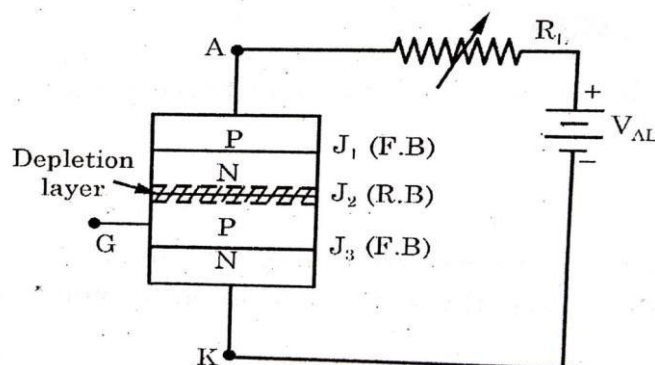

Fig. Forward Voltage Triggering

In practice this method is not employed because it needs a very large anode to cathode voltage. And also once the voltage is more than the VBO, it generates very high currents which may cause damage to the SCR. Therefore, most of the cases this type of triggering is avoided.

(2) dv/dt Triggering

In forward blocking state junctions J1 and J3 are forward biased and J2 is reverse biased. So the junction J2 behaves as a capacitor (of two conducting plates J1 and J3 with a dielectric J2) due to the space charges in the depletion region. The charging current of the capacitor is given as

$$\mathbf{I = C \, dv/ \, dt}$$

where dv/dt is the rate of change of applied voltage and C is the junction capacitance.

From the above equation, if the rate of change of the applied voltage is large that leads to increase the charging current which is enough to turn ON the SCR without a gate signal.

However, this method is also practically avoided because it is a false turn ON process. damage to it.

(3) Temperature Triggering

If the temperature of p-n junction is increased, the number of electron-hole pairs also increases. This causes to increase the leakage current and further it increases the current gains of the SCR.

By increasing the temperature at junction J2 causes the breakdown of the junction and hence it conducts. This is called temperature triggering (also called false triggering). This type of triggering is practically not employed because it causes the thermal runaway (increase in junction temperature lead to increase in current gain, which further increases the junction temperature and so on) and hence the SCR may be damaged.

(4) Light Triggering

An SCR turned ON by light radiation is also called as Light Activated SCR (LASCR). In this method, light rays with appropriate wavelength and intensity are allowed to strike the junction J2.

These types of SCRs are consisting of a niche in the inner p-layer. Therefore, when the light

struck on this niche, electron-hole pairs are generated at the junction J2 which provides additional charge carriers at the junction leads to turn ON the SCR.

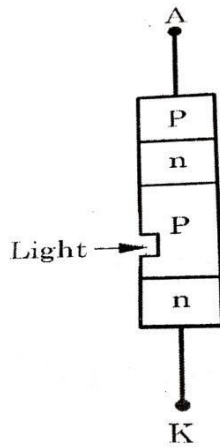

Fig. LASCR Construction View Symbol

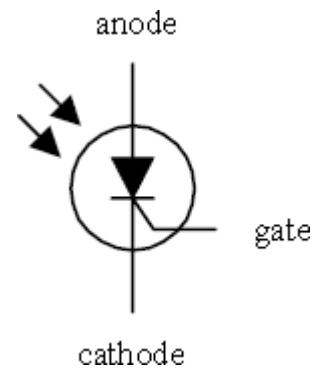

Fig. LASCR

(5) Gate Triggering

This is most common and efficient method to turn ON the SCR. When the SCR is forward biased, a sufficient voltage at the gate terminal injects some electrons into the junction J2. This results to increase reverse leakage current and hence the breakdown of junction J2 even at the voltage lower than the VBO.

Depends on the size of the SCR the gate current varies from a few milli-amps to 200 milli-amps or more. If the gate current applied is more, then more electrons are injected into the junction J2 and results to come into the conduction state at much lower applied voltage.

In gate triggering method, a positive voltage is applied between the gate and the cathode terminals. We can use the following three types of gate signals to turn On the SCR:

- (a) **DC Gate Triggering:** In this triggering, a sufficient DC voltage is applied between the gate and cathode terminals in such a way that the gate is made positive with respect to the cathode. The gate current drives the SCR into conduction mode. In this, a continuous gate signal is applied at the gate and hence causes the internal power dissipation (or more power loss).

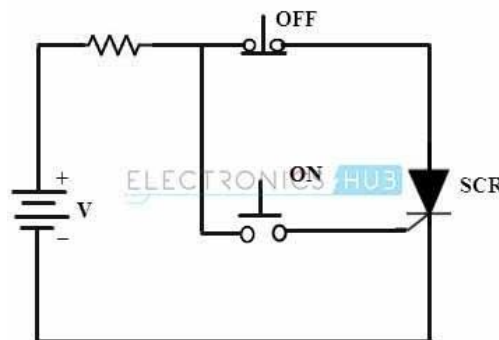

Fig. DC Gate Triggering

(b) AC GateTriggering: This is the most commonly used method for AC applications where the SCR is employed for such applications as a switching device. With the proper isolation between the power and control circuit, the SCR is triggered by the

phase-shift AC voltage derived from the main supply. The firing angle is controlled by changing the phase angle of the gate signal.

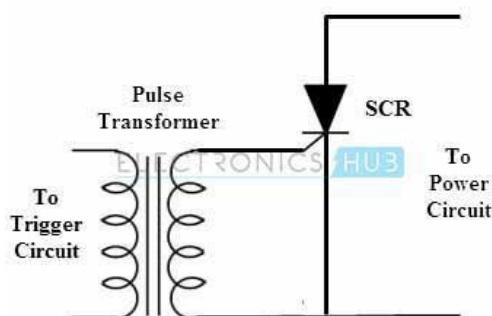

Fig. AC Gate Triggering

However, only one half of the cycle is available for the gate drive to control the firing angle and next half of the cycle a reverse voltage is applied between the gate and cathode. This is one of the limitations of AC triggering and also separate step down or pulse transformer is needed to supply the voltage to gate drive from the main supply.

(c) **Pulse Triggering:** The most popular method of triggering the SCR is the pulse triggering. In this method, gate is supplied with single pulse or a train of pulses. The main advantage of this method is that gate drive is discontinuous or doesn't need continuous pulses to turn ON the SCR and hence gate losses are reduced in greater amount by applying single or periodically appearing pulses. For isolating the gate drive from the main supply, a pulse transformer is used.

Different commutation circuits for SCR:

The process of turning OFF an SCR from an ON state is called **commutation**. To turn OFF the conducting SCR, the below conditions must be satisfied:

- 1) **The anode or forward current of SCR must be reduced to zero or below the level of holding current.**
- 2) **A sufficient reverse voltage must be applied across the SCR to regain its forward blocking state.**

The commutation techniques of thyristors are classified into two types:

1. Natural Commutation
2. Forced Commutation

1) Natural Commutation (Line Commutation):

Generally, if we consider AC supply, the current will flow through the zero crossing

line while going from positive peak to negative peak. Thus, a reverse voltage will appear across the device simultaneously, which will turn off the thyristor immediately. This process is called as natural commutation as thyristor is turned off naturally without using any external components or circuit or supply for commutation purpose. Figure below shows the Natural Commutation.

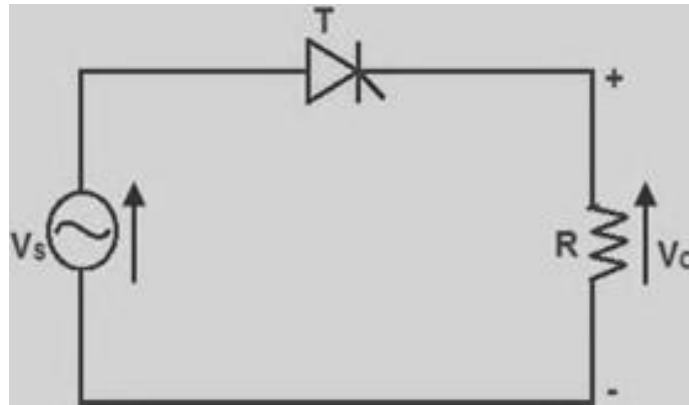

Fig. Natural Commutation

2) Forced Commutation:

The thyristor can be turned off by reverse biasing the SCR or by using active or passive components. Thyristor current can be reduced to a value below the value of holding current. Since, the thyristor is turned off forcibly it is termed as a forced commutation process. **Forced commutation can be observed while using DC supply; hence it is also called as DC commutation.** The external circuit used for forced commutation process is called as commutation circuit and the elements used in this circuit are called as commutating elements.

Classification of Forced Commutation Methods:

1. Class A Commutation

This is also known as **self commutation, or resonant commutation, or load commutation.** In this commutation, the source of commutation voltage is in the load. This load must be an under damped R-L-C supplied with a DC supply so that natural zero is obtained. The commutating components L and C are connected either parallel or series with the load resistance R as shown below.

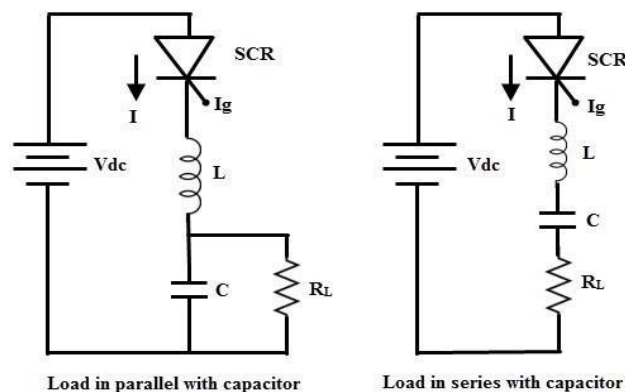

The value of load resistance and commutating components are so selected that they forms a under damped resonant circuit to produce natural zero. When the thyristor or SCR is

triggered, the forward currents starts flowing through it and during this the capacitor is charged up to the value of E.

Once the capacitor is fully charged (more than the supply source voltage) the SCR becomes reverse biased and hence the commutation of the device.

2. Class B Commutation

This is also a **self commutation** circuit in which commutation of SCR is achieved automatically by L and C components. In this, the LC resonant circuit is connected across the SCR but not in series with load as in case of class A commutation and hence the L and C components do not carry the load current.

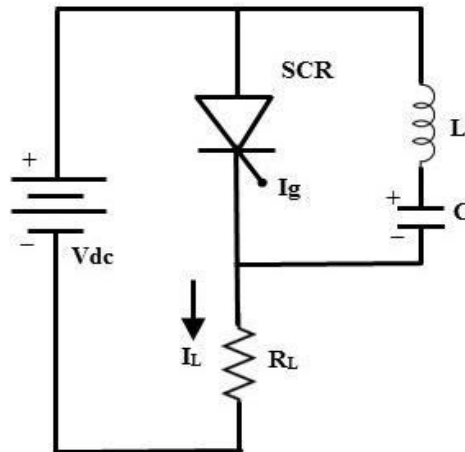

When the DC supply is applied to the circuit, the capacitor charges with an upper plate positive and lower plate negative up to the supply voltage E . When the SCR is triggered, the current flows in two directions, one is through $E+ - SCR - R - E-$ and another one is the commutating current through L and C components.

Once the SCR is turned ON, the capacitor starts discharging through $C+ - L - SCR - C-$. When the capacitor is fully discharged, it starts charging with a reverse polarity. Hence a reverse voltage applied across the SCR which causes the commutating current I_c to oppose load current I_L .

When the commutating current I_c is higher than the load current, the SCR will automatically turn OFF.

3. Class C Commutation

In this commutation method, the main SCR to be commutated is connected in series with the load and an additional or complementary SCR is connected in parallel with main SCR. This method is also called as **complementary commutation**. The figure below shows the complementary commutation.

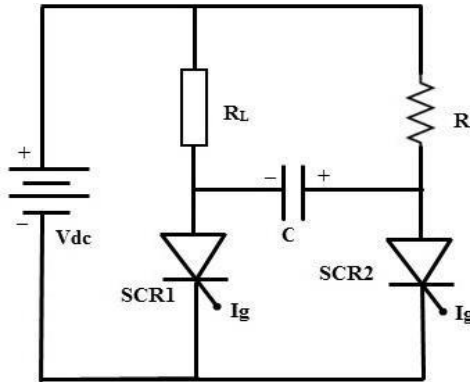

Initially, both SCRs are in OFF state so the capacitor voltage is also zero. When the SCR1 or main SCR is triggered, current starts flowing in two directions, one path is $E+ - R_L - SCR1 - E-$ and another path is the charging current $E+ - R - C+ - C- - SCR1 - E-$. Therefore, the capacitor starts charging up to the value of E .

When the SCR2 is triggered, SCR is turned ON and simultaneously a negative polarity is applied across the SCR1. So this reverse voltage across the SCR1 immediately causes to turn OFF the SCR1. Now the capacitor starts charging with a reverse polarity through the path of $E+ - R_L - C+ - C- - SCR2 - E-$. And again, if the SCR 1 is triggered, discharging current of the capacitor turns OFF the SCR2.

4. Class D Commutation

This is also called as **auxiliary commutation** because it uses an auxiliary SCR to commutate the main SCR. The main SCR with load resistance forms the power circuit while the diode D, inductor L and SCR2 forms the commutation circuit.

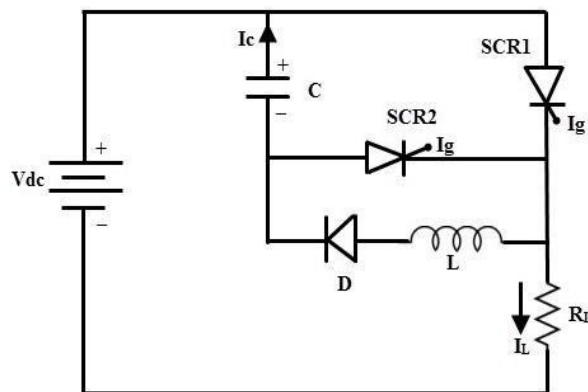

When the supply voltage E is applied, both SCRs are in OFF state and hence the capacitor voltage is zero. In order to charge the capacitor, SCR2 must be triggered first. So the capacitor charges through the path $E+ - C+ - C- - SCR2 - R_L - E-$.

When the capacitor is fully charged the SCR2 becomes turned OFF because no current flow through the SCR2 when capacitor is charged fully. If the SCR1 is triggered, the current flows in two directions; one is the load current path $E+ - SCR1 - R_L - E-$ and another one is commutation current path $C+ - SCR1 - L - D - C-$.

As soon as the capacitor completely discharges, its polarities will be reversed but due to the presence of diode the reverse discharge is not possible. When the SCR2 is triggered capacitor starts discharging through $C+ - SCR2- SCR1- C-$. When this discharging current is more than the load current the SCR1 becomes turned OFF.

5. Class E Commutation

This is also known as **external pulse commutation**. In this, an external pulse source is used to produce the reverse voltage across the SCR. The circuit below shows the class E commutation circuit which uses a pulse transformer to produce the commutating pulse.

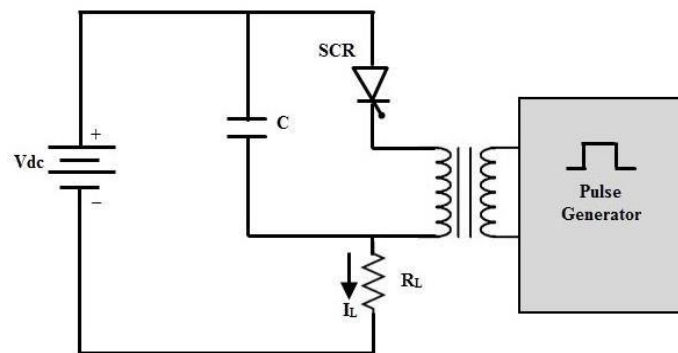

If the SCR need to be commutated, pulse duration equal to the turn OFF time of the SCR is applied. When the SCR is triggered, load current flows through the pulse transformer. If the pulse is applied to the primary of the pulse transformer, an emf or voltage is induced in the secondary of the pulse transformer.

This induced voltage is applied across the SCR as a reverse polarity and hence the SCR is turned OFF. The capacitor offers a very low or zero impedance to the high frequency pulse.

Natural Vs Forced communication:

Sr. No.	Natural commutation	Forced commutation
1	Requires AC voltage at input	Requires DC voltage at input
2	External components are not required.	External components are required.
3	Used in controlled rectifiers, AC voltage controller	Used in choppers, inverters etc.
4	SCR turns off due to negative supply voltage.	SCR turns off due to current & voltage both
5	No Power loss takes place during commutation	Power loss takes place during commutation
6	Zero cost	Significant cost

Construction, working principle and V-I characteristics of DIAC: DIAC=DIODE+AC

The DIAC stands for the **Diode AC** switch. The DIAC is a bidirectional, two terminal switching device which can be turned on by either (Positive or Negative) polarity of alternating supply voltage. The two terminals of DIAC are not named as anode and cathode as in case of normal diode. The DIAC is also called as triggering diode.

Construction, operation and V-I characteristics of DIAC:

It is a device which consists of four layers and two terminals. Figure below shows symbol and structure of the DIAC:

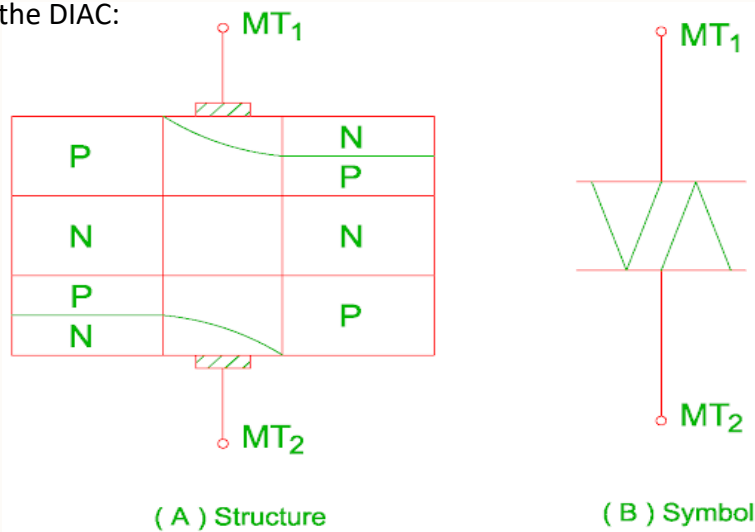

- The two terminals of the DIAC are labelled as MT1 and MT2, where MT stands for "Main Terminal."
- The Diac consists of two PNP structure which are connected in anti parallel to each other.
- The Diac conducts only when the voltage applied to its terminal is equal to break over voltage.
- When the terminal MT1 is made positive with respect to MT2 and applied voltage less than the break over voltage, only leakage current flows through the device.
- The region OA represents blocking or non conducting state as shown in the Figure below:

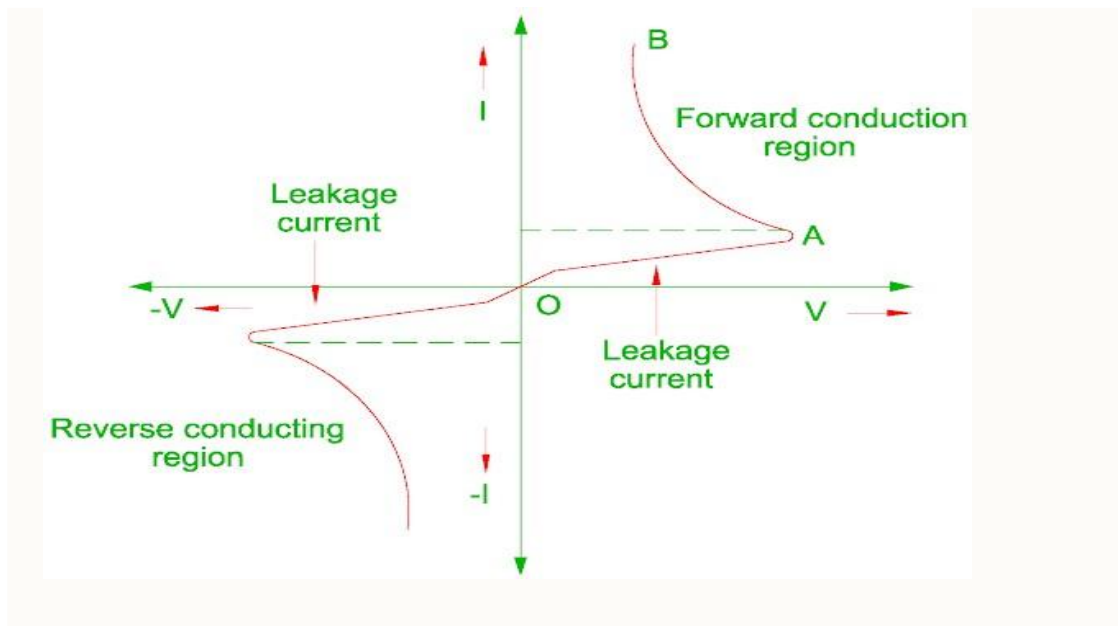

- When the voltage across its terminal reaches to break over voltage, the device starts to conduct.
- As the current through the device increases, the voltage drop across device decreases.
- The device exhibits negative resistance characteristic and region AB is known as conducting state.
- When the MT2 is made positive with respect to MT1, the device has similar characteristics as that of in the first quadrant.
- This is due to fact that the doping level is same at the two junctions of the device.
- The value of break over voltage for Diac is usually 30 voltage.

Application of Diac:

1. It can be used mainly in the TRIAC triggering circuit.
2. It can be used in the lamp dimmer circuit.
3. It is used in the heat control circuit.
4. It is used in the speed control of a universal motor.

Construction, working principle and V-I characteristics of TRIAC:

TRIAC=TRIODE+AC

“TRIAC” is an abbreviation for three terminals AC switch. ‘Tri’-indicates that the device has three terminals and ‘AC’ indicates that the device controls alternating current. It can conduct in both the directions that is whether the applied gate signal is positive or negative, it will conduct. Thus, this device can be used for AC systems as a switch. This is a three terminal, four layer, bi-directional semiconductor device. Figure below shows the symbol of TRIAC, which has two main terminals MT₁ and MT₂ connected in inverse parallel and a gate terminal.

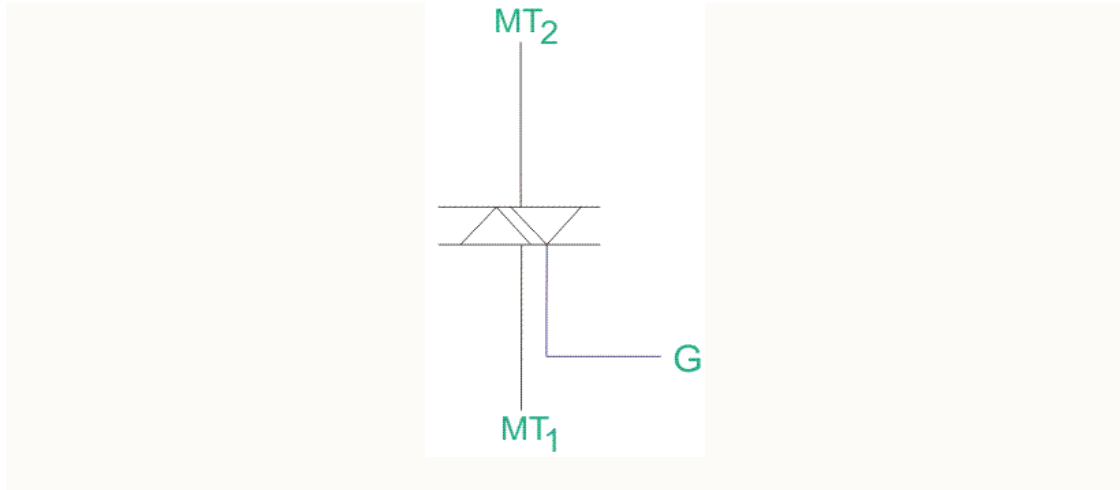

Construction of TRIAC

Two SCRs are connected in inverse parallel with gate terminal as common. Gate terminals is connected to both the N and P regions due to which gate signal may be applied which is irrespective of the polarity of the signal. Here, we do not have anode and cathode since it works for both the polarities which means that device is bilateral. It consists of three terminals namely, main terminal 1(MT₁), main terminal 2(MT₂), and gate terminal G.

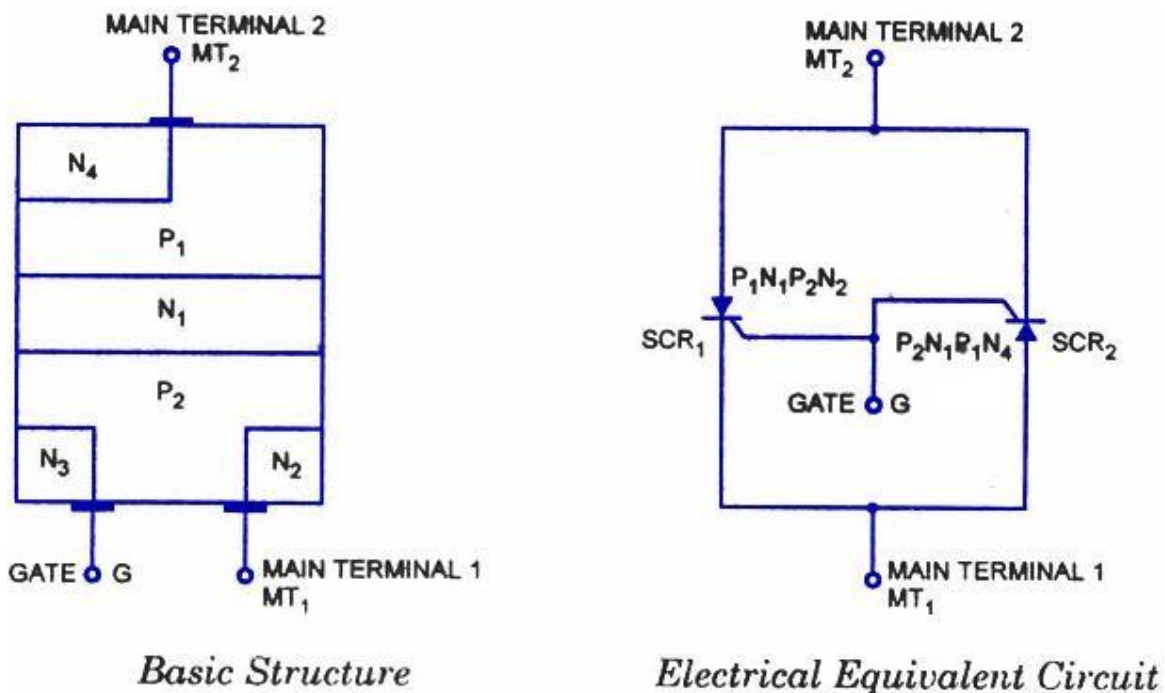

Fig. Construction of a TRIAC and its Electrical Equivalent Circuit.

Operation of Triac:

Though the TRIAC can be turned on without any gate current provided the supply voltage becomes equal to the breakover voltage of the triac but the normal way to turn on the TRIAC is by applying a proper gate current. There are four different modes of operations, they are-

1. When MT_2 and Gate being Positive with Respect to MT_1

When this happens, current flows through the path $P_1-N_1-P_2-N_2$. Here, P_1-N_1 and P_2-N_2 are forward biased but N_1-P_2 is reverse biased. The TRIAC is said to be operated

in positively biased region. Positive gate with respect to MT_1 forward biases P_2-N_2 and breakdown occurs.

2. When MT_2 is Positive but Gate is Negative with Respect to MT_1

The current flows through the path $P_1-N_1-P_2-N_2$. But P_2-N_3 is forward biased and current carriers injected into P_2 of the TRIAC.

3. When MT_2 and Gate are Negative with Respect to MT_1

Current flows through the path $P_2-N_1-P_1-N_4$. Two junctions P_2-N_1 and P_1-N_4 are forward biased but the junction N_1-P_1 is reverse biased. The TRIAC is said to be in the negatively biased region.

4. When MT_2 is Negative but Gate is Positive with Respect to MT_1

P_2-N_2 is forward biased at that condition. Current carriers are injected so the TRIAC turns on. This mode of operation has a disadvantage that it should not be used for high (di/dt) circuits. Sensitivity of triggering in mode 2 and 3 is high and if marginal triggering capability is required, negative gate pulses should be used. Triggering in mode 1 is more sensitive than mode 2 and mode 3.

v-I Characteristics of a TRIAC

The TRIAC characteristics are similar to SCR but it is applicable to both positive and negative TRIAC voltages. The TRIAC can conduct in two quadrants (quadrant I and quadrant III) with either a positive or negative gate voltage is applied. As like SCR, the TRIAC remains in OFF state until the breakdown voltage V_{BO} is not reached. When gate signal is applied, the breakdown voltage will be reduced.

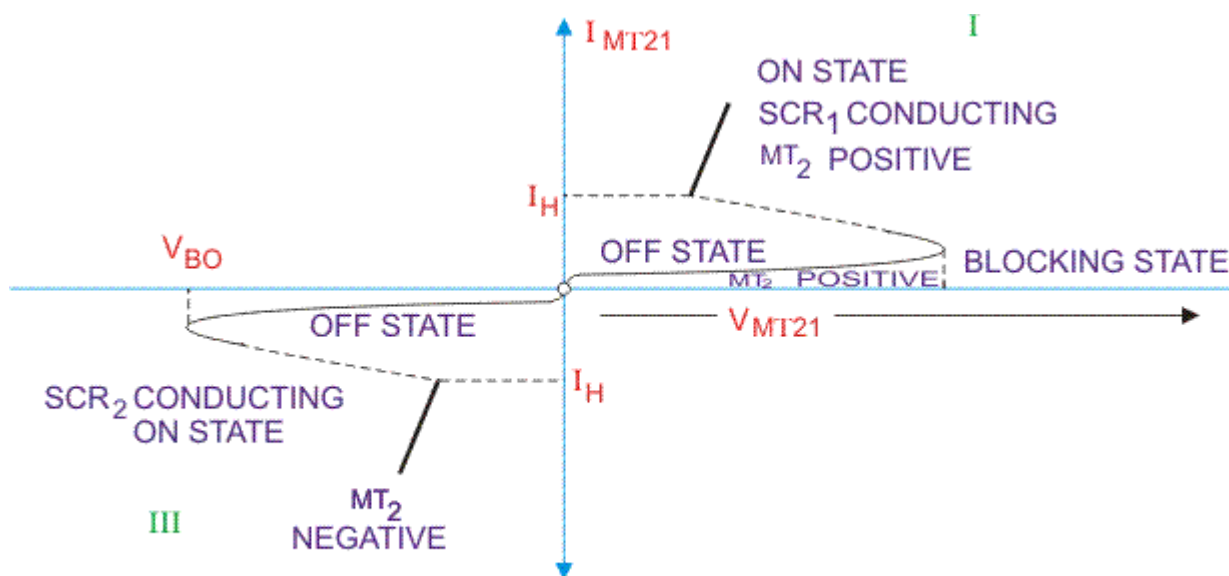

V-I Characteristic of a Triac

Applications of TRIAC

1. They are used in control circuits.
2. It is used in High power lamp switching.
3. The TRIAC is most commonly used semiconductor device for switching and power control of AC systems as the TRIAC can be switched "ON" by either a positive or negative Gate pulse.

4. TRIACs are used in light dimmers, speed controls for electric fans and other electric motors.

Uni-junction Transistor (UJT):

UJT stands for UniJunction Transistor. It is a three terminal semiconductor switching device. The unique switching characteristics of UJT makes it different from conventional BJT's and FET's by acting as switching transistor instead of amplifying the signals. It exhibits negative resistance in its characteristics which employs it as relaxation oscillators in variety of applications.

Symbol and Construction of Unijunction Transistor (UJT):

In Uni-junction Transistor, the PN Junction is formed by lightly doped N type silicon bar with heavily doped P type material on one side. The ohmic contact on either ends of the silicon bar is termed as Base 1 (B_1) and Base 2 (B_2) and contact on P-type terminal is named as Emitter. The Uni-junction transistor has only one junction; hence the name is UNI-junction transistor.

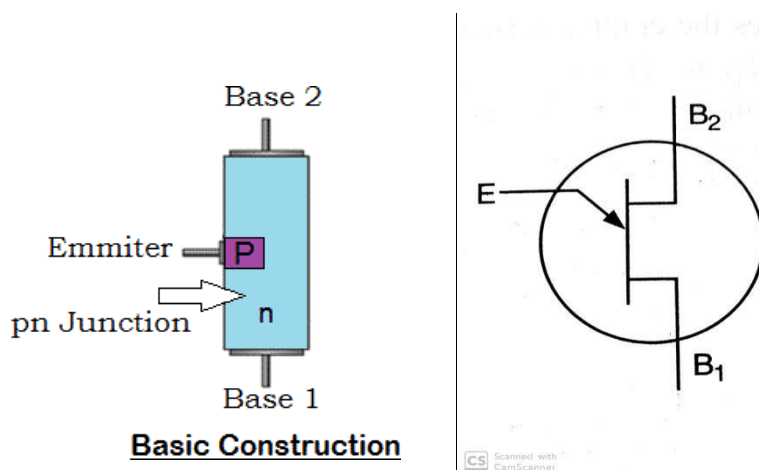

Fig.– Basic Construction & Symbol of Unijunction Transistor (UJT)

The emitter junction is placed such that it is more close to terminal B_2 than B_1 .

Working of Unijunction Transistor (UJT) works

The simplified equivalent circuit below shows that N-type channel consists of two resistors RB_2 and RB_1 in series with an equivalent diode, D representing the PN junction.

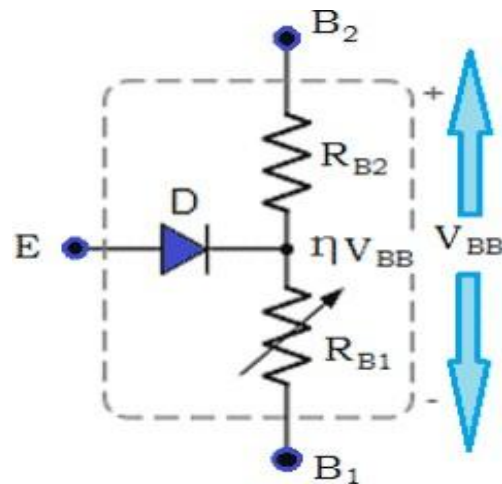

Fig. – Simplified Equivalent Circuit of Unijunction Transistor (UJT)

The resistance between the Emitter (E) and Base 1 is R_{B1} , whereas between the Emitter (E) and Base 2 is R_{B2} . Since the PN junction is more close to B_2 , the value of R_{B2} will be less than the variable resistance R_{B1} .

The lightly doped N type layer acts as base and heavily doped P type layer works as emitter.

A voltage divider network is formed by the series resistances R_{B2} and R_{B1} . When a voltage is applied across the semiconductor device, the potential will be in proportion to the position of base points along the channel.

The Emitter (E) will act as input when employed in a circuit and the terminal B_1 will be grounded. The terminal B_2 will be positive biased to B_1 , when a voltage (V_{BB}) is applied across the terminals B_1 and B_2 .

When the emitter input is zero, the voltage across resistance R_{B1} of the voltage divider circuit is calculated by

$$V_{RB1} = \frac{R_{B1}}{R_{B1} + R_{B2}} * V_{BB}$$

Where, $R_{B1} + R_{B2} = R_{BB}$ is known as interbase resistance. The important parameter of Unijunction Transistor is '**intrinsic stand-off ratio**' (η), which is resistive ratio of R_{B1} to

R_{BB} .

Therefore, $\eta = \frac{R_{B1}}{R_{B1} + R_{B2}}$ and $V_{RB1} = \eta * V_{BB}$

If an external voltage V_E is connected to the emitter, the equivalent circuit can be redrawn as:

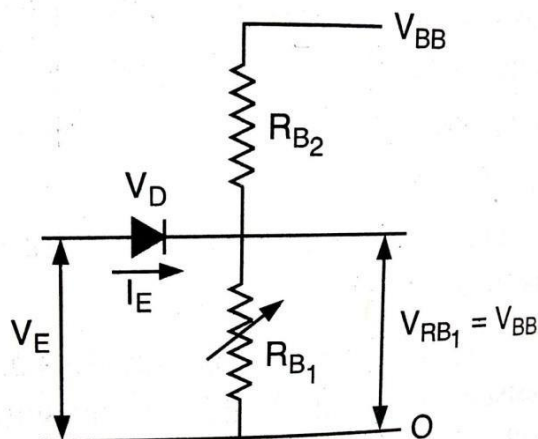

If V_E is less than V_{RB1} , the diode is reversed biased and the circuit behaves as if the emitter is open circuit. If V_E is increased and it becomes higher than $\eta V_{BB} + V_D$, the diode becomes forward biased and emitter current I_E flows into base 1 region. Here, V_D is forward diode voltage. Because of this, value of R_{B1} decreases. Further increase in V_E causes the emitter current to increase which in turn reduces R_{B1} and this causes a further increase in current. This runaway effect is called **regeneration**. The value of emitter voltage at which this occurs is known as **peak voltage V_P** and is given by:

$$V_P = \eta V_{BB} + V_D$$

v-I Characteristics of Uni-junction Transistor (UJT):

The characteristics of Unijunction Transistor (UJT) can be explained by three parameters:

- Cutoff
- Negative Resistance Region
- Saturation

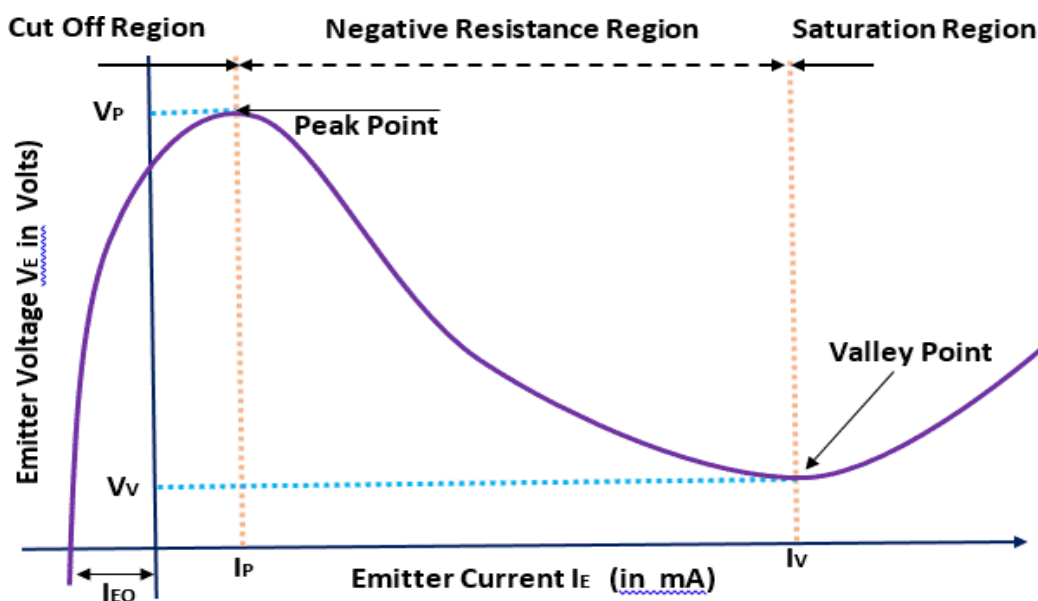

Fig. – Characteristics of Unijunction Transistor (UJT)

Cutoff

Cutoff region is the area where the Unijunction Transistor (UJT) doesn't get sufficient voltage to turn on. The applied voltage is less than peak voltage V_P , thus making transistor to be in off state.

Negative Resistance Region

When the emitter voltage is increased up to peak point, V_P , the Unijunction Transistor (UJT) will turn on. At this point the emitter current increases rapidly until the valley point is reached where the device runs into saturation. The voltage drops from V_P to Valley Point even though the current increases (negative resistance). The region in between peak point and valley point is most important region and is called negative resistance region. In this region with increase in emitter voltage, emitter current goes on increasing with decrease in emitter voltage.

Saturation

Saturation region is the area where the current and voltage raises, if the applied voltage to emitter terminal increases.

Application of Unijunction Transistor (UJT) in Relaxation Oscillator:

UJT Relaxation Oscillator can be practically viewed by the following circuit.

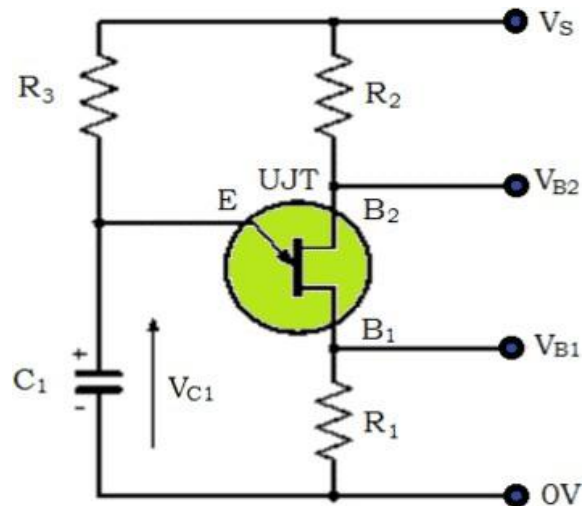
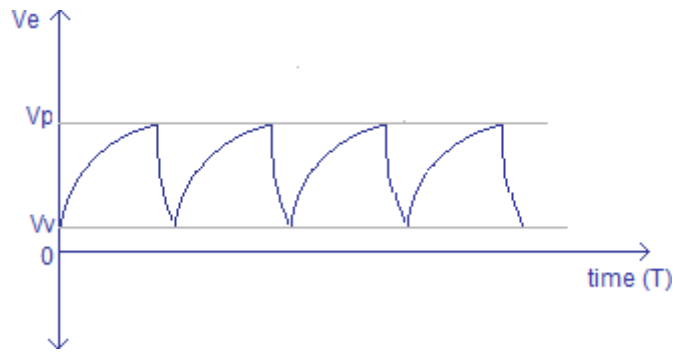

Fig.– Use of Unijunction Transistor (UJT) in Relaxation Oscillator

The resistance R_3 charges the capacitor C_1 until the peak point. The UJT's emitter terminal has no effect on C_1 until peak point is reached. When the emitter voltage reaches peak voltage point, the lowered emitter base 1 resistance rapidly discharges the capacitor.

As the capacitor C_1 discharges beneath the valley point, the emitter base 1 resistance will return back to high resistance, thus making capacitor free to charge again. This cycle is repeated and results in a sort of sawtooth waveform across the capacitor. The saw tooth waveform across the capacitor of a typical UJT relaxation oscillator is shown in the figure below.



Wave form across the capacitor in a UJT relaxation oscillator

Heat Sinks:

Every thyristor has some semiconductor junction. When current flows through a junction, it produces some heat. This heat increases the junction temperature and if this heat is not removed at an adequate rate from the junction, the junction can be damaged permanently.

To keep junction temperature constant, thyristors are mounted on Heat Sinks which take heat from the case of thyristor and transfer it to the surroundings (Ambient). Heat sinks are devices that enhance heat dissipation from a hot surface, usually the case of a heat generating component, to a cooler ambient, usually air. When heat dissipated by Heat Sink becomes equal to heat produced by thyristor, a steady junction temperature is achieved.

The heat transfer of a device can be explained with the help of electrical analog of a device which is mounted on a heat sink as shown in fig.

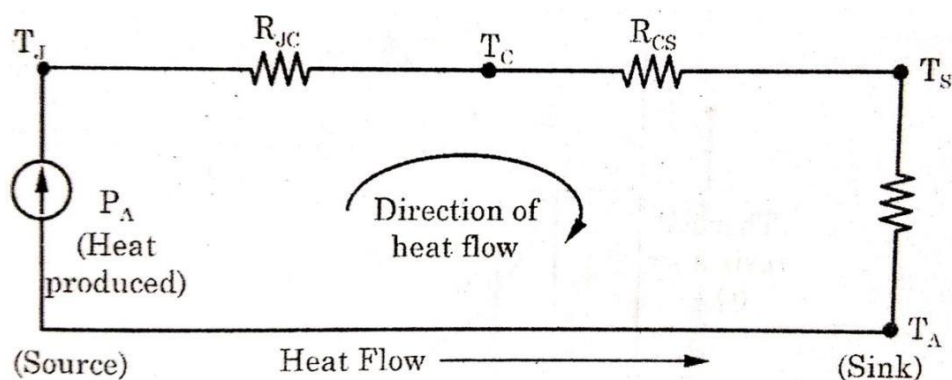

Fig.-Electrical Analog of Heat Transfer

In above fig., P_A = Device power loss; T_J = Junction temp.; T_C = Case temp.; T_S = Sink temp.; T_A = Ambient temp.; R_{JC} = Thermal resistance between junction to case; R_{CS} = Thermal resistance between case to sink; R_{SA} = Thermal resistance between sink to ambient.

- Different modes of heat transfer are (i) Conduction (ii) Convection and (iii) Radiation
- Heat from Junction to Case is transferred through Conduction.

- Heat from Case to Heat Sink is transferred through Conduction.
- Heat from Heat Sink to Ambient is transferred through Convection and Radiation. Convection can be natural or forced by external source.

Selection of Heat Sinks:

- In selecting an appropriate heat sink thermal resistance from sink to ambient must be known. R_{JC} and R_{CS} values are given by the manufacturers. Once the device power loss (P_A) is known, the required thermal resistance (R_{SA}) is calculated for known ambient temperature (T_A) using following formula:

$$T_J = P_A (R_{JC} + R_{CS} + R_{SA})$$

- After that next step is to choose a heat sink and its size as per the requirement of the thermal resistance.
- Copper and Aluminum heat sinks are preferred.
- Copper is better heat sink than Aluminum because thermal resistance of Aluminum is more than copper.
- Due to light weight, low cost and high heat storage capacity, Aluminum is more popular heat sink.
- For same value of thermal resistance, heat sink of Aluminum has to be of higher surface area than heat sink of copper.
- If more heat is to be dissipated, heat sink with fins can be used to increase the surface area for better dissipation of heat through convection as shown below:

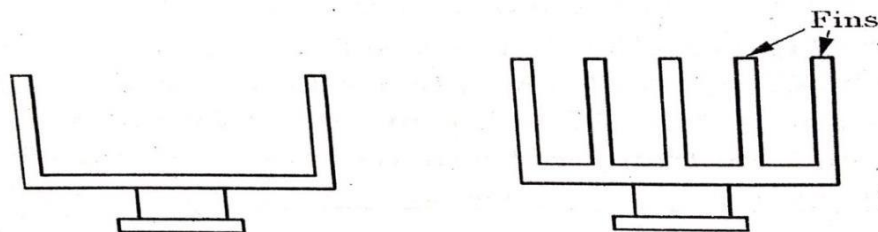

Fig.-Heat Sinks with Fins

- In case where surface area is constant or increase in surface area does not give required results, forced air cooling is used.

- In case very high power thyristors, water and oil cooling heat exchanger arrangements are used.

- Heat sinks should be painted black so that they can lose heat through radiation.
- Silicon grease is applied between case and sink to minimize the thermal resistance between two.

Light intensity control/Fan Regulator (Using DIAC and TRIAC):

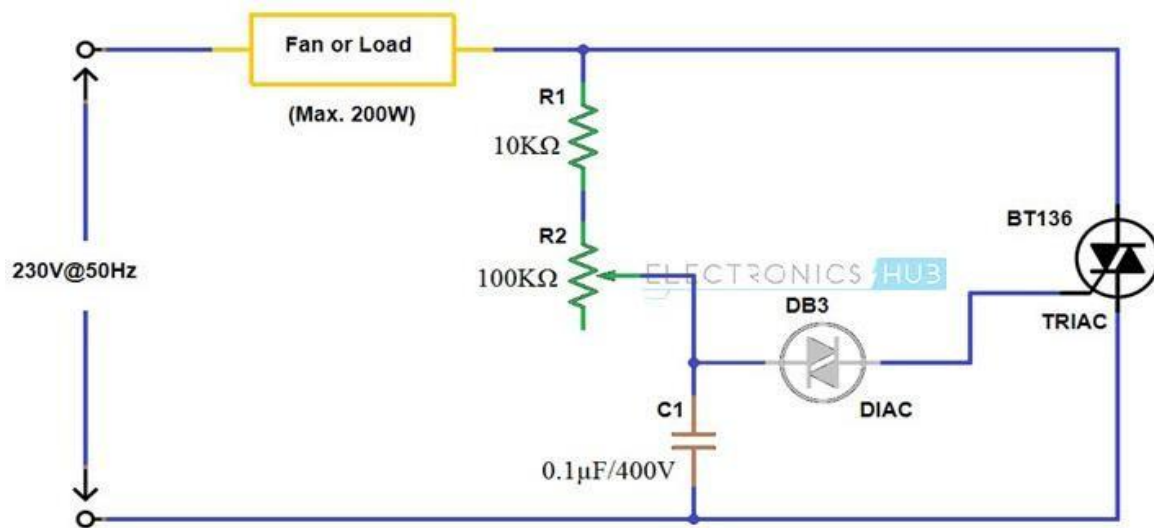

Fig. – Circuit Diagram for Light Intensity Control/Fan Regulator

Working:

- Before giving the power supply to this simple Light intensity control/Fan regulator circuit, keep the variable resistor or potentiometer in maximum resistance position so that no triggering is applied to TRIAC and hence the TRIAC will be in cut-off mode.
- Turn ON the power supply of the circuit and observe whether the bulb/fan is in off/standstill condition or not. Vary the potentiometer position slowly so that the capacitor starts charging at the time constant determined by the values of R1 and R2.
- Once the voltage across the capacitor is more than the break over voltage of the DIAC, DIAC starts conducting. Thus, the capacitor starts discharging towards the gate terminal of TRIAC through DIAC.
- Therefore, TRIAC starts conducting and hence the main current starts flowing into the bulb/fan through the closed path formed by TRIAC.
- By varying the potentiometer R2, the rate at which capacitor is going to be charged get varied this means that if the resistance is less, the capacitor will charge at a faster rate so the earlier will be the conduction of TRIAC.
- As the potentiometer resistance gradually increases, the conduction angle of TRIAC will be reduced. Hence the average power across the load will be varied. In this way light intensity/fan speed can be controlled.
- Due to the bidirectional control capability of both TRIAC and DIAC, it is possible to control the firing angle of the TRIAC in both positive and negative peaks of the input.

Battery Charger:

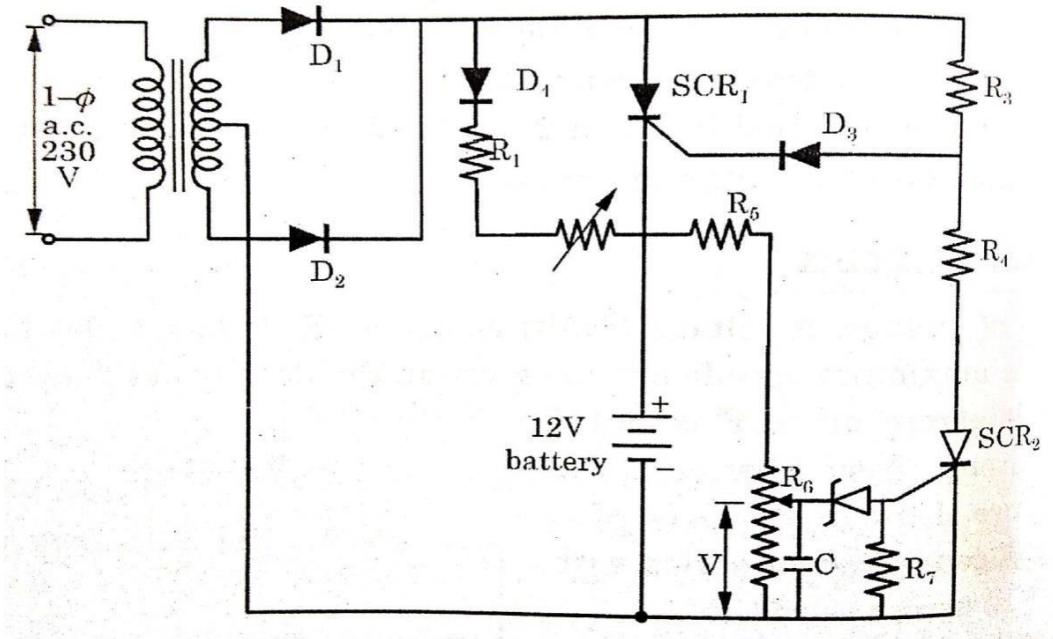

Fig. – Battery Charging Circuit

Working:

- A centre tapped transformer along with diodes D1 and D2 generate the full wave rectified voltage.
- Rectified voltage is applied to SCR1, which makes it forward biased. Same voltage is applied to gate of SCR1 through R3 and D3, which turns ON the SCR1 and battery starts charging.
- When battery charging is near to completion, voltage V across the capacitor C, reaches to a value near to zener breakdown voltage and hence gate current will flow into SCR2 and it start conducting.
- Once SCR2 is ON, voltage divider formed by R3 and R4 will reverse bias the diode D3 and as a result SCR1 will be turned OFF.
- Therefore charging of battery is stopped.
- Diode D4 and resistances R1, R2 are used to continue the flow of charging current into battery when quick charging is over.

Speed control of universal motors:

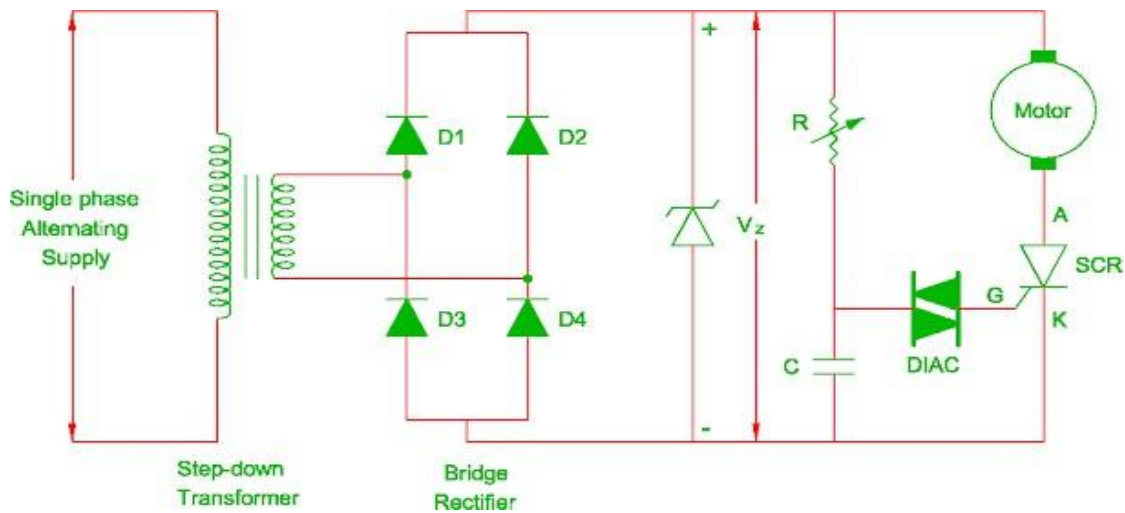

Fig. – Speed Control of Universal Motor

- The speed control of universal motor is shown in above figure.
 - The single phase bridge rectifier converts alternating voltage into direct voltage.
 - The zener diode provides constant voltage to RC circuit.
 - The charging of capacitor is done through variable resistor R.
- When the voltage across capacitor becomes equal to DIAC break over voltage, the DIAC turns on.
- The gate terminal of SCR receives gate pulse and therefore it turns on. As soon as the SCR turns on, current passes through universal motor.
 - The discharging of capacitor is done through DIAC and gate cathode circuit.
 - The speed control of DC motor is done through variable resistor R.
 - This will result in speed of universal motor decreases.